



Key Features:

- Favorite of broadcast show hosts and voice-over studios
- Ideal for instrument recording, especially kick drums and acoustic guitars
- Studio condenser response yet no powering required and immune to overloading
- Large Acoustalloy diaphragm and low-mass aluminum voice coil
- Dual-ported, continuously Variable-D® with minimal proximity effect
- Steel case and hum-bucking coil provide exceptional magnetic shielding



General Description:

The Electro-Voice RE20 is a professional-quality dynamic cardioid microphone created specially for recording, broadcast and sound-reinforcement applications requiring essentially flat response over a very wide frequency range. The wide frequency response, coupled with excellent transient response, make the RE20 easily comparable to the finest condenser cardioid microphones and an easily operated "bass tilt down" switch corrects spectrum balance for use in long-reach situations or other applications where bass attenuation is needed.

A true cardioid microphone, the RE20 offers greatest rejection at 180° off axis - directly to the rear of the microphone. Pattern control is so consistent that the frequency response is nearly independent of angular location of the sound source, creating virtually no off-axis coloration, yet providing greatest possible rejection of unwanted sounds. An integral blast and wind filter covers each acoustic opening on the RE20. In recording sessions or on stage, singers can "close talk" the microphone, singing with their lips almost touching the grille screen with no worry of "P-pops" or excessive sibilance. Part of the filter also shock mounts the internal microphone element, reducing the transfer of vibrations from external sources. The exceptional performance of the RE20 is achieved by using a large Acoustalloy diaphragm in combination with an exceptionally low-mass aluminum voice coil. Using this diaphragm assembly, the RE20 is capable of reproducing extremely high sound pressure levels with no fear of the overload and distortion often experienced with phantom-powered condensers. The RE20 will also continue to function flawlessly in high humidity and elevated temperatures that would seriously degrade competitive condenser microphones. A massive steel housing and effective hum-bucking coil assure the RE20's resistance to magnetically induced hum and noise. This means the RE20 can be used successfully in situations where other microphones would experience unacceptable

Technical Specifications:

Generating Element:	Dynamic
Frequency Response:	45 - 18,000 Hz
Polar Pattern:	Cardioid
Impedance:	150 ohms balanced
Sensitivity, Open Circuit Voltage:	1.5 mV/pascal = 1 kHz
Power Level, 1 kHz (0 dB = 1 mV/Pascal):	-57 dB
Hum Pickup Level, typical (60 Hz/ 1 millioersted field):	-130 dBm
Polarity:	Pin 2 will be positive referenced to Pin 3 with positive pressure on diaphragm
Case Material:	Steel
Dimensions,	
Length:	216.7 mm (8.53 in.)
Widest Diameter:	54.4 mm (2.14 in.)
Body Diameter:	49.2 mm (1.94 in.)
Finish:	Fawn Beige
Net Weight:	737 g (1 lb, 10 oz)
Shipping Weight:	1,474 g (3 lb, 4 oz)
Accessories Furnished:	81715 stand clamp
Optional Accessories:	309A shock-mounted stand adapter for use with floor stand or recording boom

levels of hum and buzz. By exploiting the strength of its steel housing and employing a mechanical nesting concept, EV designers have created an exceptionally rugged microphone with superior handling noise rejection ideally suited for professional uses.

Frequency Response:

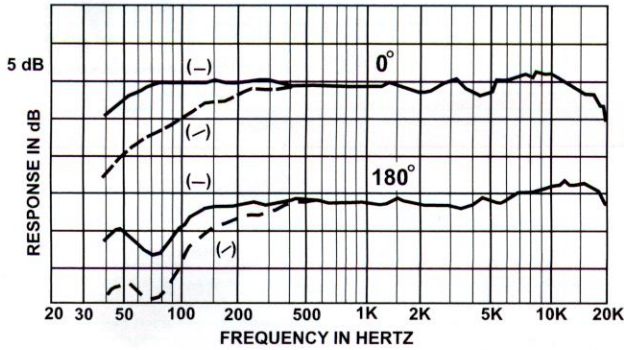

General Description (cont'):

The bass-boosting proximity effect common to most directional microphones when used close to the sound source, is eliminated in the RE20. This is accomplished via the application of the EV-exclusive Variable-D® technology. By controlling the effect of microphone proximity, the RE20 can be located very close to sound sources without a loss in clarity or definition making the RE20 ideal for tight vocals and challenging instruments. It can be used inside bass drums, on acoustic guitars, and is found in voice booths and broadcasting studios everywhere.

Architects' and Engineers' Specifications:

The microphone shall be a cardioid type with integral blast filter protecting all acoustic openings. The blast filter shall also serve as a shock mount for the internal microphone element. The microphone shall have a wide-range uniform frequency response from 45-18,000 Hz. An integral passive network shall be provided so that when the filter switch is in the "on" position, low-frequency response shall tilt down 4.5 dB from 400-100 Hz. With switch in "off" position, microphone shall be essentially "flat" from 80-6,000 Hz, with a broad 2.5 dB rise in response from 6,000-14,000 Hz, and nominally down 3 dB at 18,000 Hz. Response below 80 Hz shall be nominally down 3 dB at 45 Hz. Output level shall be -57 dB (0 dB = 1 mW/Pascal). Nominal impedance of 150 ohms. Response at any angular position away from the major axis shall be essentially similar to the response on the major axis, but attenuated uniformly at all frequencies by an amount appropriate to that angular position. Attenuation at frequencies from 45-10,000 Hz (refer to major axis signal value) shall exceed 15 dB at 180° from major axis in any plane. Attenuation above 10,000 Hz shall exceed 13 dB. Polar characteristics shall be sufficiently uniform in all planes so that it is, effectively, a cardioid of revolution. There shall be a shield to prevent dust and iron particles from reaching the diaphragm. The case shall be made of steel. The microphone shall have a maximum diameter of 54.4 mm (2.14 in.), a body diameter of 49.2 mm (1.94 in.) and a length of 216.7 mm (8.53 in.). Finish shall be a nonreflecting fawn beige. A stand adapter shall be supplied. The Electro-Voice RE20 is specified.

Wiring Diagram:

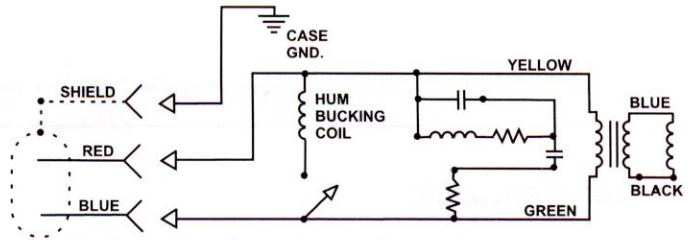

Polar Response:

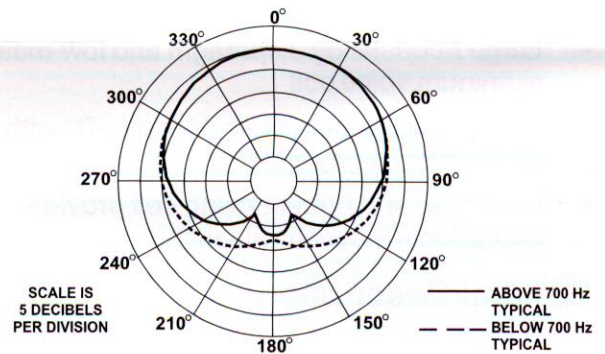

Disassembly:

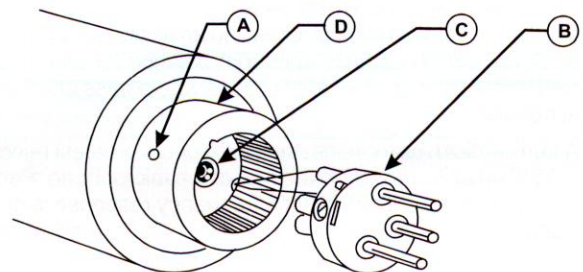

Dimension Drawing:

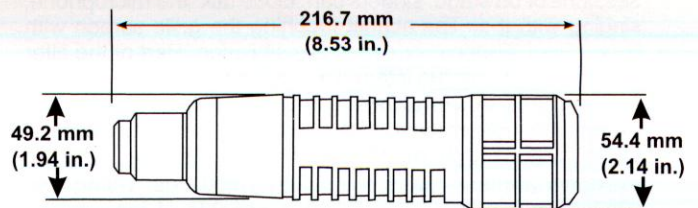

RE20 Part Number:
• 16207816

EV Electro-Voice®

12000 Portland Avenue South, Burnsville, MN 55337
Phone: 952/884-4051, Fax: 952/884-0043

www.electrovoice.com

© Telex Communications, Inc. 9/2003
Part Number 534678 Rev C

U.S.A. and Canada only. For customer orders, contact Customer Service at:
800/392-3497 Fax: 800/955-6831

Europe, Africa, and Middle East only. For customer orders, contact Customer Service at:
+ 49 9421-706 0 Fax: + 49 9421-706 265

Other International locations. For customer orders, contact Customer Service at:
+ 1 952 884-4051 Fax: + 1 952 736-4212

For warranty repair or service information, contact the Service Repair department at:
800/553-5992 or 402/467-5321

For technical assistance, contact Technical Support at:
800/392-3497 or 952/736-4656

Specifications subject to change without notice.